



# STREET & STRIP OIL PANS

## - Big Block Chevy -

### LOW PROFILE

This pan is equally suited for use on the street or the race track. Fits all Chevy chassis, including 1966 & 67 Chevelles, except 1962-67 Nova & 55-57 Chevy. Oil control baffles are used to provide consistent oil pressure and subdue any unwanted, power robbing oil movement. Pan rail on Mark IV, Mk V & Gen VI is notched for up to 4½" strokes with most aluminum rods without modification. Comes with a high strength magnetic drain plug.

**Pan Capacity is 7 Qts. Plus Filter**

Sump: Length 9 1/2" , Depth 8 1/2"

- Mark IV Engine (1965-90) ..... **30950**
- Mark V & VI Engine (8.2 Litre) ..... **30955**

*Oil Pump and Pick-Up Required:*

Pick-Up .....	18301
Pick-Up, Extreme Duty .....	18201
Oil Pump, (Melling M77HV, 10990) .....	18760
Oil Pump Shaft .....	23060
Oil Pan Gasket - Mark IV .....	40200
1 Piece Pan Gasket - Mark V & Gen VI .....	41002
Oil Pan Bolts .....	85005
Oil Pan Studs .....	81305
Windage Tray .....	32200 or 32260
Windage Tray Install Kit .....	81151
Rear Pan Baffle .....	32505
Oil Pan Dipstick .....	22010

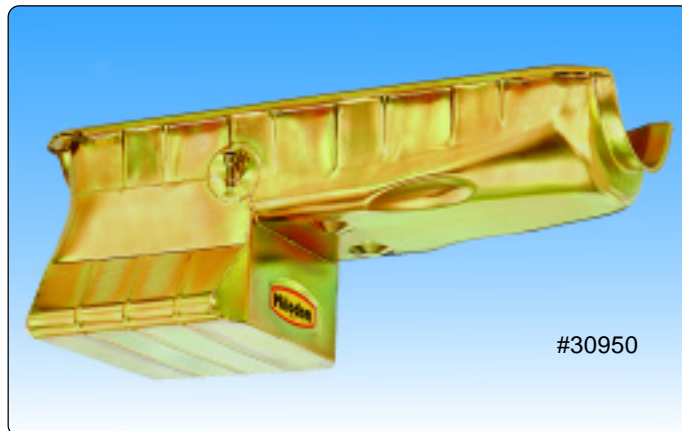

#30950

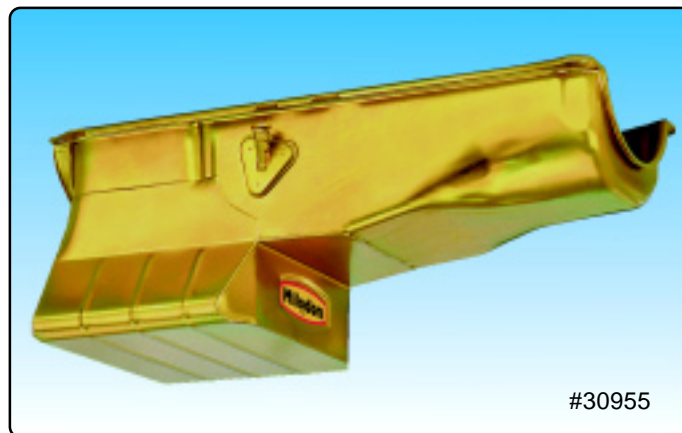

#30955

### LOW PROFILE WITH OIL FILTER RELIEF

Same as the Low Profile design except that it has an oil filter cut-out allowing the oil filter to exit straight down. These days big inch engines are the norm. They all use large tube headers to breath correctly and these larger tube headers will enclose the filter area making removal difficult and very messy. This pan performs just as well but makes life much easier. Comes with a high strength magnetic drain plug.

**Pan Capacity is 6 Qts. Plus Filter**

Sump: Length 9 1/2" , Depth 8 1/2"

- Mark IV Engine (1965-90) ..... **30951**
- Mark V & VI Engine (8.2 Litre) ..... **30956**

Pick-Up .....	18301
Pick-Up, Extreme Duty .....	18201
Oil Pump, (Melling M77HV, 10990) .....	18760
Oil Pump Shaft .....	23060
Oil Pan Gasket - Mark IV .....	40200
1 Piece Pan Gasket - Mark V & Gen VI .....	41002
Oil Pan Bolts .....	85005
Oil Pan Studs .....	81305
Windage Tray .....	32200 or 32260
Windage Tray Install Kit .....	81151
Rear Pan Baffle .....	32505
Oil Pan Dipstick .....	22010

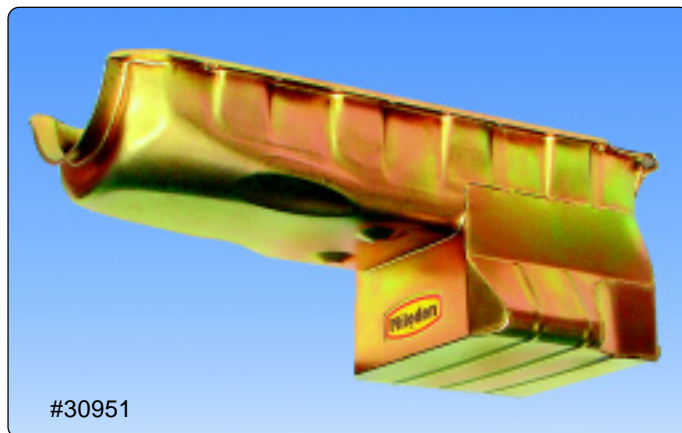

#30951



# STREET & STRIP OIL PANS

- Big Block Chevy -

## EXTRA LOW PROFILE AND 55-56-57 CHEVY

For the early 1955, 56 and 57 Chevy chassis, as well as, very low Camaros / Chevelles. Pan is ready for use on the street or the race track. This pan allows adequate steering clearance even if the engine is moved forward, as many mount kits do. Includes high strength magnetic drain plug.

Will fit a 4 1/2" strokes with most aluminum rods.

**Pan Capacity is 6 Qts. Plus Filter**

Sump: 8 1/8" Long, 7 3/4" Deep

- 396-454 Mark IV Engine (1965-90) ..... **30970**
- 454-502 Mark V & VI Engine ..... **30975**

*Oil Pump and Pick-Up Required:*

Pick-Up for 30970 .....	18302
Pick-Up for 30975 .....	18303
Oil Pump, (Melling M77HV, 10990) .....	18760
Oil Pump Shaft .....	23060
Oil Pan Gasket - Mark IV .....	40200
1 Piece Pan Gasket - Mark V & Gen VI .....	41002
Windage Tray .....	32200 or 32260
Windage Tray Install Kit .....	81151
Rear Pan Baffle .....	32505
Oil Pan Dipstick .....	22010



#30970



## DEEP SUMP

For all Chevy chassis and 1955-57 Chevy if motor is mounted rearward, except 1962-67 Nova. Has oil control baffles to 100% contain oil movement to yield increased horsepower. Includes high strength magnetic drain plug.

Will fit a 4 1/2" strokes with most aluminum rods.

**Pan Capacity is 7 Qts. Plus Filter — 9 1/2" Deep Sump**

- 396-454 Mark IV Engine (1965-90) ..... **31100**
- 454-502 Mark V & VI Engine ..... **31105**

*Oil Pump and Pick-Up Required:*

Pick-Up .....	18300
Pick-Up, Extreme Duty .....	18200
Oil Pump, (Melling M77HV) .....	18760
Oil Pump Shaft .....	23060
Oil Pan Gasket - Mark IV .....	40200
1 Piece Pan Gasket - Mark V & Gen VI .....	41002
Windage Tray .....	32260 or 32200
Windage Tray Install Kit .....	81151
Rear Pan Baffle .....	32505
Oil Pan Dipstick .....	22010



#31100

## 62-67 CHEVY II NOVA

Special pan to swap a 396, 454 or 502 engine into the 1962-67 Chevy II. Features notched rear sump for steering clearance but will not fit with power steering.

Will fit a 4 1/2" strokes with most aluminum rods.

**Pan Capacity is 6 Qts. Plus Filter — 9 1/2" Deep Sump**

- 396-454 Mark IV Engine (1965-90) ..... **31110**
- 454-502 Mark V & VI Engine ..... **31115**

*Oil Pump and Pick-Up Required:*

Pick-Up .....	18300
Pick-Up, Extreme Duty .....	18200
Oil Pump, (Melling M77HV) .....	18760
Oil Pump Shaft .....	23060
Oil Pan Gasket - Mark IV .....	40200
1 Piece Pan Gasket - Mark V & Gen VI .....	41002
Windage Tray .....	32260 or 32200
Windage Tray Install Kit .....	81151
Rear Pan Baffle .....	32505
Oil Pan Dipstick - Mark IV .....	22010

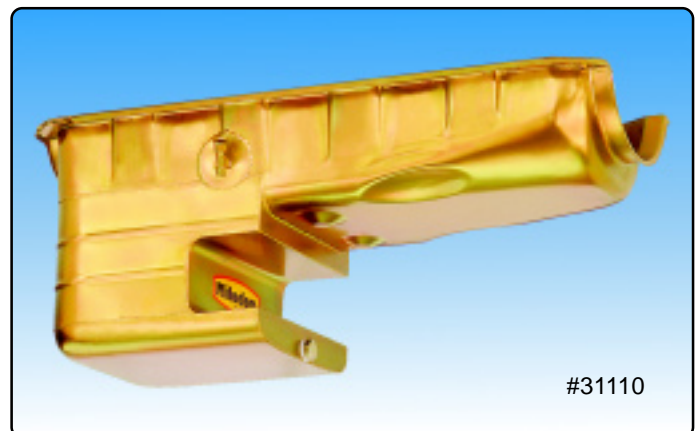

#31110