



ROAD RACE OIL PANS

- Small Block Chevy, Wet Sump -

ROAD RACE

The hot tip for road racing due to trap door baffle system proven to provide good oil supply on left and right turns. Proven highly effective in SCCA and other competition. Fits Corvettes, Camaros and most popular chassis. Comes with a high strength magnetic drain plug.

* Will fit a 4" stroker and Carillo or Eagle style rods *

**Pan Capacity is 7 Qts. Plus Filter —
10" Sump Length, 7 7/8" Sump Depth**

- Left Hand Dipstick (Up to 1979 block) **31505**
- Right Hand Dipstick, Dart SHP & 1980-85 **31506**
- Right Hand Dipstick, 1986 & Up **31508**

Oil Pump and Pick-Up Required:

Milodon 18770, (Melling M99HV)	18465
Windage Tray	32250 or 32100
Windage Tray Install Kit	81150
Rear Pan Baffle	32500
Oil Pan Gasket- 55-79	40100
Pan Gasket, 1 piece, 1955-79	41000
Pan Gasket, 1 piece, Dart SHP block	41008
Pan Bolts	85000
Pan Studs	81300

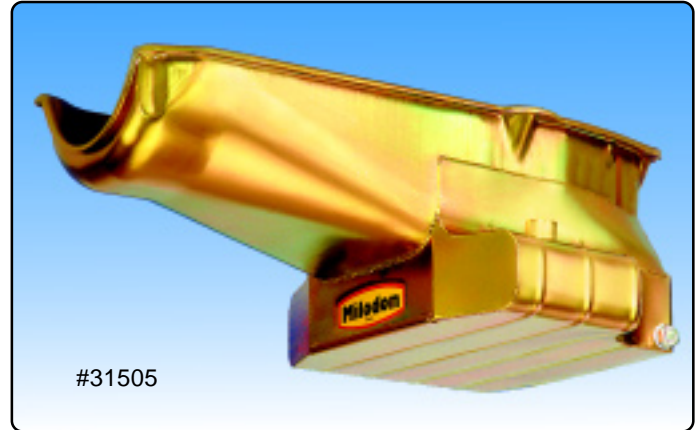

#31505



- LS Series Chevy, Wet Sump -

ROAD RACE

Just out for the LS Chevy engines, a full on road racing pan with competition trap door baffle system proven to provide good oil supply on left and right turns. Fits Corvettes, Camaros and most popular chassis. Uses billet filter fitting block that provides increased endurance race length sealing. High strength magnetic drain plug included. Will allow a 4.125" stroke.

**Pan Capacity is 7 Qts. Plus Filter —
Sump: 9 1/2" Long, 13 3/8" Wide, 5 3/8" Deep**

- LS1, LS2, LS3, LS6, LS7 **31507**

Oil Pump and Pick-Up Required:

Pickup	18292
Windage Tray	32150
Remote Oil Filter Kit	21575
Pan Bolts	85002
Dipstick	22006

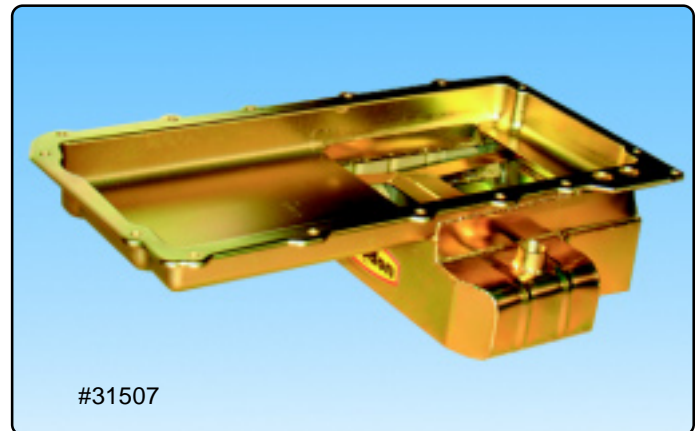

#31507

- Small Block Chevy, Dry Sump -

PRO COMPETITION - DRY SUMP

Designed to be equally effective in all types of racing, drag racing, road racing or circle track. Three 12AN fittings are used in the front, middle and rear positions. A high efficiency screen oil separator de-aerates the recovered oil before it is returned to the tank. Pro Competition design features full kick-out for maximum oil control and horsepower output. Requires small style starter.

* Will fit a 4" stroker and Carillo or Eagle style rods *

Measures 4" Under Crank, 5 1/2" Deep Reservoir

- Left & Right Hand Blocks and Dart SHP block **31700**

1 Piece Oil Pan Gasket - 55-79	41000
Pan Bolts	85000
Pan Studs	81300

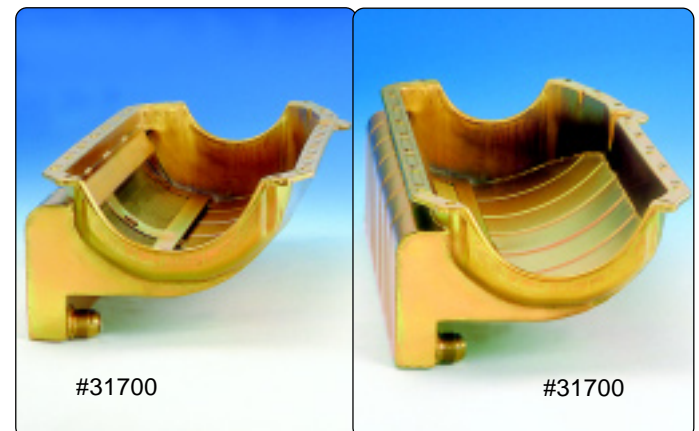

#31700

#31700



ROAD RACE OIL PANS

- Ford 1965-73 Front Sump - 289, 302 & 351W-

ROAD RACE & COBRA - FRONT SUMP

Front sump design for road race applications in pre-74 chassis. Features multiple baffles to provide oil supply during violent turns, acceleration and deceleration. Has a 1/2" pipe temperature sender bung. Fits most stock chassis using front sump pan. High strength magnetic drain plug included.

- 289-302 **31600**
Pan Capacity is 7 Qts. Plus Filter — 7½" Sump Depth

Oil Pump and Pick-Up Required:

Pickup with 18800 pump, (Melling M68HV)	18485
Oil Pump	18800
Oil Pump Shaft	22500
Oil Pan Gasket	40300
1 Piece Oil Pan Gasket	41003
Windage Tray	32210
Tray Install Kit	81157

- 351W **31630**
Pan Capacity is 7 Qts. Plus Filter — 7½" Sump Depth

Oil Pump and Pick-Up Required:

Pickup with Melling M83HV pump	18505
Oil Pump Shaft	22560
Oil Pan Gasket	40350
1 Piece Oil Pan Gasket	41004
Windage Tray	32215
Tray Install Kit	81167

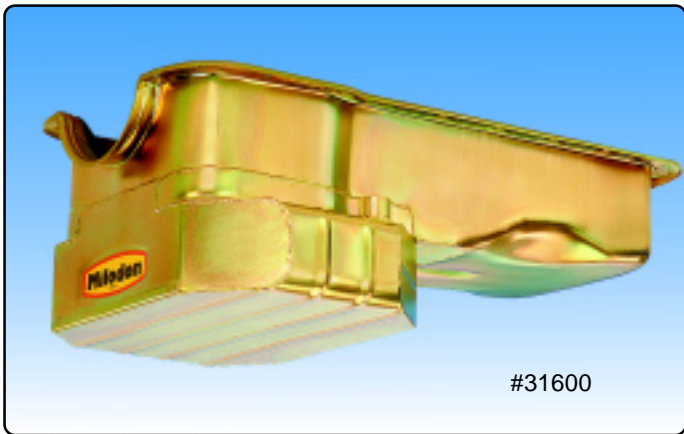

#31600

- Ford 1980 & Up Rear Sump - 302 & 351W-

LATE MODEL MUSTANG 302 ROAD RACE - REAR SUMP

Late model rear sump sump design for use in road race applications in 1978 and up chassis. While designed for the late model Mustang this pan will fit Cobra kit cars and any vehicle with clearance under the engine. Features multiple baffles to provide oil supply during violent turns, acceleration and deceleration. Uses a factory style dirt-tight screw-in dipstick and has a 1/2" pipe fitting for an oil temp sender. Comes with a high strength magnetic drain plug.

- 302 / 5.0 Liter **31601**
Pan Capacity is 7 Qts. Plus Filter — 7½" Sump Depth

Oil Pump and Pick-Up Required:

Pickup with 18800 pump, (Melling M68HV)	18491
Oil Pump Shaft	22500
Oil Pan Gasket	40300
1 Piece Oil Pan Gasket	41003
Windage Tray	32212
Tray Install Kit	81157



#31601

351W ROAD RACE - REAR SUMP

For 351 W in stock chassis 79 & up Mustangs.

- 351W **31631**
Pan Capacity is 7 Qts. Plus Filter — 7½" Sump Depth

Oil Pump and Pick-Up Required:

Pickup with Melling M83HV pump	18510
Oil Pump Shaft	22560
Oil Pan Gasket	40350
1 Piece Oil Pan Gasket	41004
Windage Tray	32215
Tray Install Kit	81167





ROAD RACE OIL PANS

- Big Block Chevy -

ROAD RACE

The hot tip for road racing due to trap door baffle system is to provide adequate oil supply on left & right turns. Proven highly effective in SCCA and other competition. Fits 396-454 engines in Corvette and other modified chassis. High strength magnetic drain plug included.

Will fit 4½" stroke with most aluminum rods.

Pan Capacity is 8 Qts. Plus Filter —

10" Sump Length, 16" Sump Width, 8 1/8" Sump Depth

- 396-454 Mark IV **31555**

Oil Pump and Pick-Up Required:

Milodon 18760, (Melling M77HV)	18465
Oil Pump Shaft	23060
Windage Tray	32260 or 32200
Windage Tray Install Kit	81151
Rear Pan Baffle	32505
Oil Pan gasket	40200

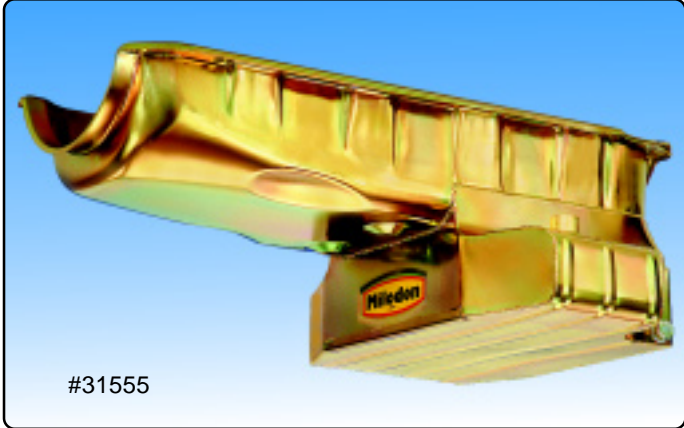

#31555



TO ACHIEVE THE PROPER DIPSTICK READING: Fill the Empty Pan with the Number of Quarts Listed in this Catalog. Listed Capacities Are For the Oil Pan ONLY and DO NOT Include the Filter. Before Starting the Engine, Check the Dipstick and Scribe the New Full Level Where the Oil Mark Is. The Original Full Mark Has No Bearing on Where Your New **Milodon** Pan Full Level Will Be.

- Ford 427, 428-

COBRA ROAD RACE - FRONT SUMP

Designed for the original Cobras and current 390, 427, 428 Cobra kit cars, as well as Road Race pre-1973 Mustangs. Road race pans work for all applications as they have the ability to control oil through acceleration, deceleration and right & left turns. Has 1/2" temperature sender bung and high strength magnetic drain plug.

Pan Capacity is 7 Qts. Plus Filter — 6" Sump Depth

- 390, 427, 428 **31650**

Oil Pump and Pick-Up Required:

Pickup	18515
Oil Pump	M57HV
Oil Pump Shaft	22550
Oil Pan Gasket	40450
Windage Tray	32224

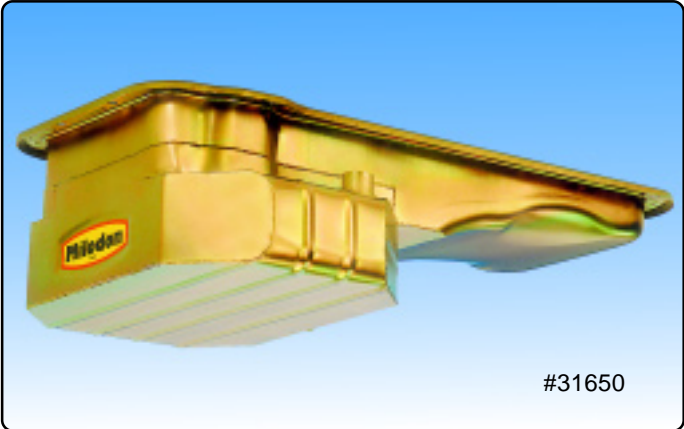

#31650

- Ford 351C -

PANTERA ROAD RACE

Designed to meet the increased demands street and road racing of the Ford Pantera. Capable of accomodating heavy acceleration, deceleration and hard turns. Features an extensive trap door and baffle system to ensure ample oil supply. High strength magnetic drain plug included.

Pan Capacity is 6 Qts. Plus Filter — 7¾" Sump Depth

- 351 Cleveland **31483**

Oil Pump and Pick-Up Required:

Pickup	18483
Oil Pump	M84AHV
Oil Pump Shaft	22565
Oil Pan Gasket	40400
Windage Tray	32222
Tray Install Kit	81151



#31483



ROAD RACE OIL PANS

- MOPAR 5.7 / 6.1 HEMI -

NEW CHALLENGER & CHARGER ROAD RACE

Designed for very low street cars as well as true road race use. A stock location front sump pan for use in the new stock Challenger, Charger chassis. Wide sump increases capacity yet allows ample ground clearance. Fully baffled for competition use. Stock steering will not interfere with pan. High strength magnetic drain plug included.

Pan Capacity is 7 Qts. Plus Filter —

Sump: 8 7/8" Long, 13 1/4" Wide, 5 1/2" Deep

- 5.7, 6.1, 392 Stroker, 426 Stroker **31001**

Oil Pump and Pick-Up Required:

Pickup	18333
Windage Tray, All Strokes	32010
Pan Gaskets, Pair	40750
Pan Bolts	85025

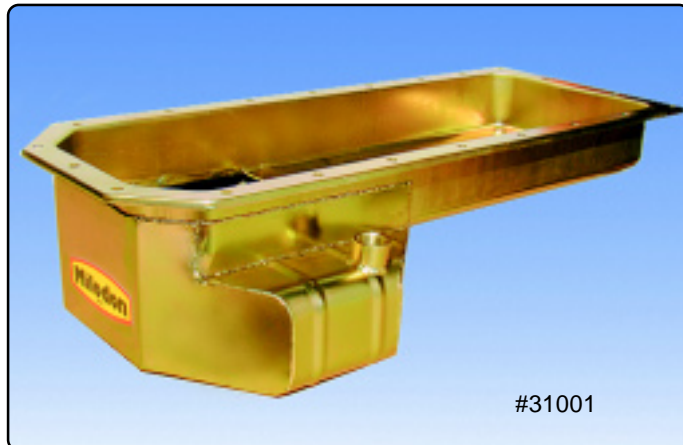

#31001

DODGE TRUCK AND DURANGO ROAD RACE

Designed for very low street trucks giving true road race performance. A stock location rear sump pan for use in the new stock trucks and Durango chassis. Wide sump increases capacity yet allows ample ground clearance. Fully baffled for competition use. Stock steering will not interfere with pan. High strength magnetic drain plug included.

Pan Capacity is 7 Qts. Plus Filter —

Sump: 8 7/8" Long, 13 1/4" Wide, 5 1/2" Deep

- 5.7, 6.1, 392 Stroker, 426 Stroker **31002**

Oil Pump and Pick-Up Required:

Pickup	18334
Windage Tray, All Strokes	32010
Pan Gaskets, Pair	40750
Dipstick 5.7 / 6.1, Billet Stainless Steel	22065
Pan Bolts	85025

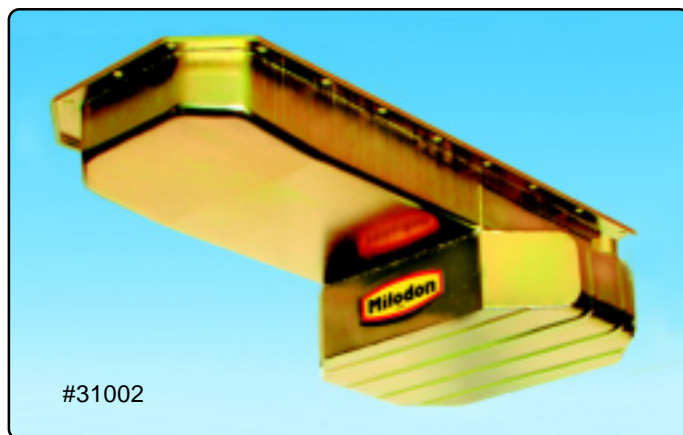

#31002



- Small Block MOPAR-

340 / 360 & STROKERS ROAD RACE

Fits A, B and E bodies. Works with 1967 to 73 and later 1973 to 1976 A body K-members. Full competition baffling with 5 doors and 7 baffle assemblies are capable of handling full road coarse use or just street on very low cars. High strength magnetic drain plug included. Clears 4.125" stroke.

Pan Capacity is 6 Qts. Plus Filter — 7" Sump Depth

- 318 / 340 **31590**
- 360 **31595**

Oil Pump and Pick-Up Required:

Pickup	18343
Oil Pump	M72HV
Oil Pan Gasket 318 / 340	40600
Oil Pan Gasket 318 / 340	40600
Oil Pan Gasket 360	40650
Oil Pump Drive Steel Gear	21530
Oil Pump Drive Bronze Gear	21535
Windage Tray	32230
Windage Install Kit	81151
Dipstick, Billet Stainless Steel	22060
Pan Bolts	85020
Pan Studs	81320

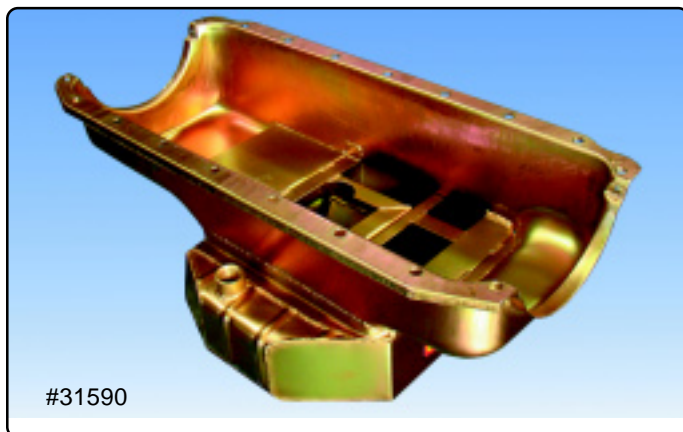

#31590



ROAD RACE OIL PANS

- Big Block MOPAR -

383-426-440 ROAD RACE

Designed for low street cars as well as road race use. A stock location sump pan for use in stock Chrysler B & E body chassis. Wide sump increases capacity yet allows ample ground clearance. Fully baffled for competition use. Stock steering will not interfere with this pan. High strength magnetic drain plug included.

Pan Capacity is 7 Qts. Plus Filter — 5½" Sump Depth

- 383-440 **31580**

Oil Pump and Pick-Up Required:

Pickup, 3/8" Pipe Inlet	18328
Pickup, 1/2" Pipe Inlet	18338
Oil Pump	M63HV
Oil Pan Gasket	40700
Oil Pump Shaft	21505 or 21525
Windage Tray	32000
Windage Tray, up to 3/4" Stroker	32005
Dipstick, Billet Stainless Steel	22070
Pan Bolts	85020
Pan Studs	81320

383-426-440 ROAD RACE

WITH EXTERNAL PICKUP

Same as the 31580 oil pan but with an external pickup exiting the pan. This 12AN port is a must for big inch strokers and mandatory on World / Mopar blocks with a big stroke as the existing internal pickup boss must be machined away. Comes complete with the pickup installed in the pan. High strength magnetic drain plug included.

Pan Capacity is 7 Qts. Plus Filter — 5½" Sump Depth

- 383-440 **31581**

Oil Pump and Pick-Up Required:

Oil Sstem	21001
Oil Pump	M63HV
Oil Pan Gasket	40700
Oil Pump Shaft	21505 or 21525

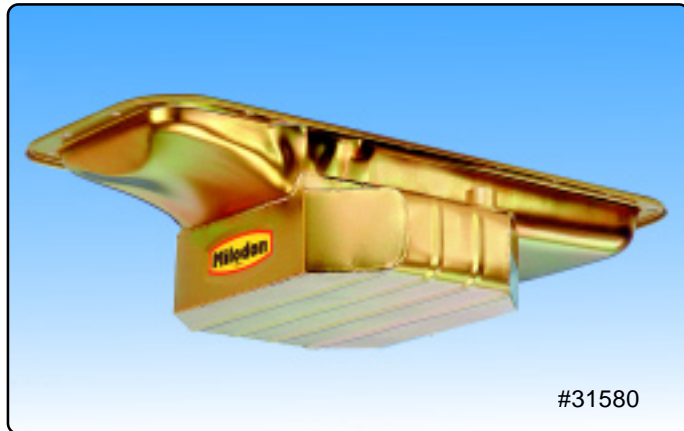

#31580



- AMC -

AMC & JEEP - PRO TOURING

EXTERNAL PICKUP SYSTEM

Designed for maximum performance with maximum ground clearance for very low cars. Whether a high power track car that handles very well or a street car that is really low, this pan is your answer. Increased capacity with full competition baffling allows a pan that is shallower than stock to carry 8 quarts. High volume external pickup system provides adequate oil supply for 7000 RPM plus for extended periods. Pan pickup exits away from header tubes to avoid contact. High strength magnetic drainplug included.

Pan Capacity is 8 Qts. Plus Filter — 7" Sump Depth

- 304, 343, 360, 390, 401 **31680**
- Pick-Up System 24055

AMC & JEEP - PRO TOURING

INTERNAL PICKUP

Designed for unequaled performance with maximum ground clearance for very low cars. Increased capacity with full competition baffling system allows a pan that is shallower than stock to carry 8 quarts. Internal pickup system provides adequate oil supply for up to 6800 RPM. High strength magnetic drainplug included.

Pan Capacity is 8 Qts. Plus Filter — 7" Sump Depth

- 304, 343, 360, 390, 401 **31681**
- Pick-Up 18401

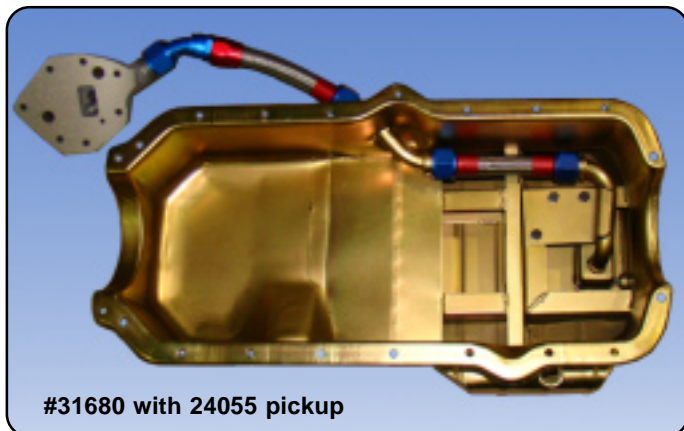

#31680 with 24055 pickup

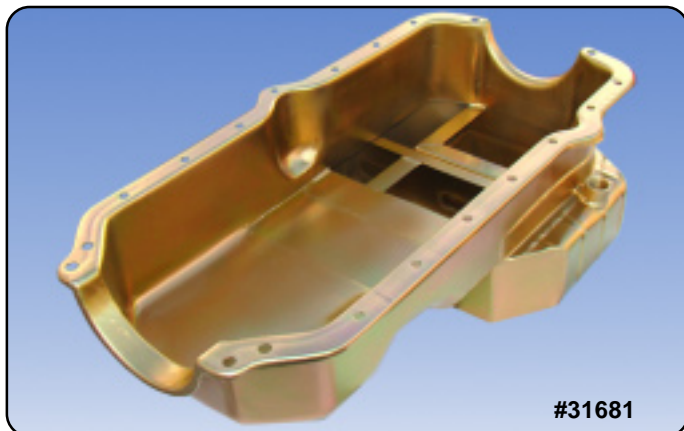

#31681



ROAD RACE OIL PANS

- Pontiac-

ROAD RACE - GTO

Designed for 1964 to 73 GTO, LeMans with 389-455 engines in performance street and road racing where, heavy acceleration, deceleration and hard turns are involved. Features trap door, baffle system and increased oil capacity to ensure ample oil supply. Angled sump front allows adequate crossmember clearance to install the engine and trans together. Fits well with Dougs Headers with all size header tubes. Will not fit Firebird chassis. High strength magnetic drain plug included.

Pan Capacity is 7 Qts. Plus Filter — 7³/₄" Sump Depth

- 389-455 **31665**

Oil Pump and Pick-Up Required:

Pickup	18525
Oil Pump, 3/4" inlet.....	M54D
Oil Pan Gasket.....	40900
Oil Pan Bolts	85020
Oil Pan Studs	81320
Windage Tray	32240
Tray Install Kit	81151

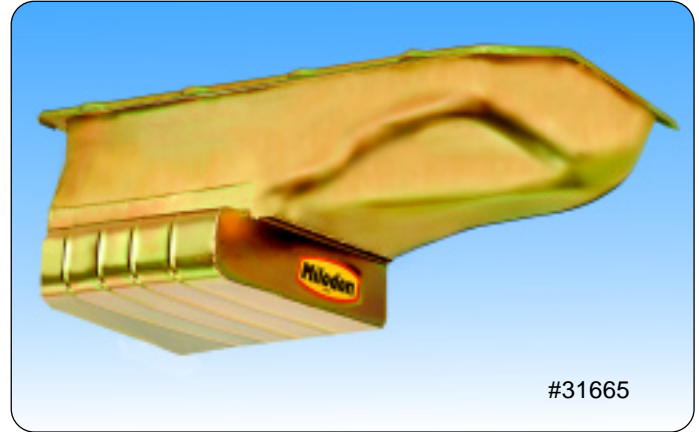

#31665

ROAD RACE - FIREBIRD

Designed originally for performance street and road racing in the 1967 to 1974 Firebird, where heavy acceleration, deceleration and hard turns are involved. Features trap door, baffle system and increased oil capacity to ensure ample oil supply. Pan has straight, non kicked out sides to allow easy starter removal and extra header clearance. Fits 389-455 Pontiac engines in the Firebird as well as all other 1966 & up GTO and LeMans chassis. High strength magnetic drain plug included.

Pan Capacity is 6 Qts. Plus Filter — 7³/₄" Sump Depth

- 389-455 **31660**

Oil Pump and Pick-Up Required:

Pickup	18525
Oil Pump, 3/4" inlet.....	M54D
Oil Pan Gasket.....	40900
Oil Pan Bolts	85020
Oil Pan Studs	81320
Windage Tray	32240
Tray Install Kit	81151

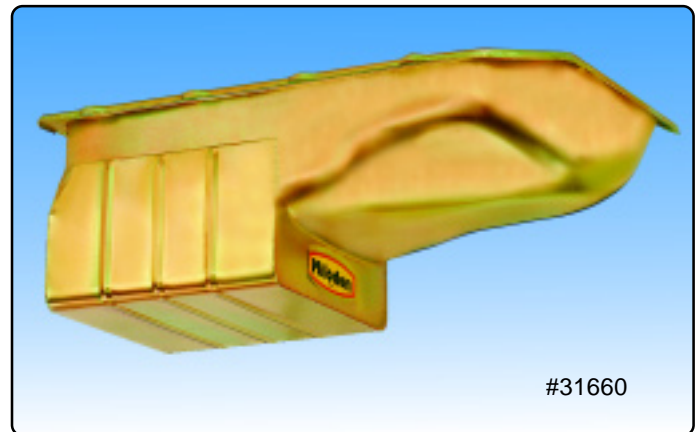

#31660



*Pick-Up to Pan Bottom Clearance **MUST** Be Checked and Adjusted from 1/4" to 3/8".*