



4 x 4 TRUCK & OFF-ROAD OIL PANS

- **Designed for Rough Terrain Operation.**
- **Fully Horizontal Baffled to Keep Oil in Sump.**
- **All are for Applications with Sump in the Rear.**
- **All Pick-Ups are Heavily Braced for Added Strength.**
- **Carry Large Oil Capacity to Help Control Oil Temperature.**



- Small Block Chevy -

DEEP SUMP

One-piece stamped pan features ultra straight rails (no gasket leaks) and has built-in horizontal baffle for oil control. Fits all 2 & 4WD chassis applications suitable for street or full-on, off-road racing. High strength magnetic drain plug included. Strokes up to 3.750".

Pan Capacity is 6 Qts. Plus Filter — 8½" Sump Depth

- 350-400 (Up To 1979, Left hand dipstick) **30401**

Oil Pump and Pick-Up Required:

Pickup	18314
Oil Pump (Melling M55HV)	18750
Oil Pump Shaft	23050
Windage Tray 350	32250 or 32100
Windage Tray 400	32250 or 32102
Windage Tray Install Kit	81150
Rear Pan Baffle	32500
Oil Pan Gasket	40100
1 Piece Pan Gasket	41000
Dipstick	22000



#30401

- Big Block Chevy -

DEEP SUMP

Designed for all 2 and 4 wheel drive trucks. Will provide 100% oil control and decreased oil temperatures in all conditions whether all out racing or just street. Will accept up to 4 1/12" stroke. High strength magnetic drain plug included.

Pan Capacity is 7 Qts. Plus Filter — 9½" Sump Depth

- 396-454 Mark IV ('65-'90) **31100**
- 8.2 Litre Mark V & VI **31105**

Oil Pump and Pick-Up Required:

Pickup	18300
Pickup Extreme Duty	18200
Oil Pump (Melling M77HV)	18760
Oil Pump Shaft	23060
Windage Tray	32260 or 32200
Windage Tray Install Kit	81151
Rear Pan Baffle	32505
Oil Pan Gasket, Mark IV	40200
1 Piece Pan Gasket - Mk V & Gen VI	41002
Dipstick	22010



#31100



4 x 4 TRUCK & OFF-ROAD OIL PANS

- Ford -

4.6 & 5.4 LITER MODULAR TRUCK

Special off-road pan for 2 and 4 wheel drive, rear sump trucks. Deep sump in rear for extra capacity, features horizontal baffles for increased oil control. Features dirt and water tight Ford style screw-in dipstick receiver.

**Pan Capacity is 7 Qts. Plus Filter —
Sump Measures 10" Deep in Rear**

- Ford 4.6 & 5.4 Liter (Trucks, Broncos 1994 & Up).. . **30450**

Oil Pump and Pick-Up Required:

Pickup	Stock
Dipstick	22029

Pick-Up to Pan Bottom Clearance MUST Be Checked and Adjusted from 1/4" to 3/8".

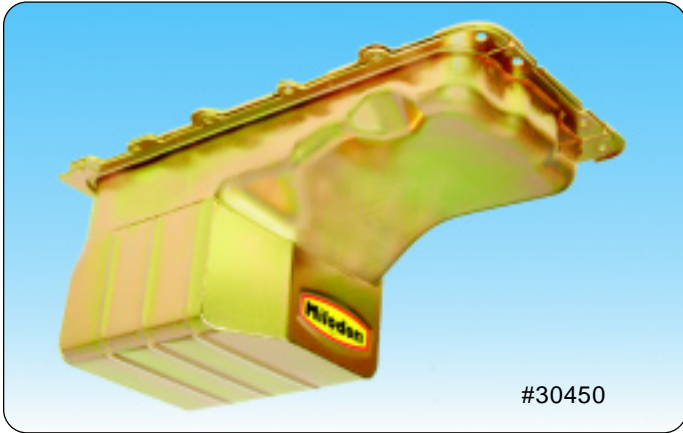

#30450

289, 302 BRONCO REAR SUMP

Special off-road pan for 2 and 4 wheel drive, rear sump trucks and 1966 & Up Broncos. Deep sump in rear for extra capacity, features horizontal baffles for increased oil control. Features dirt and water tight Ford style screw-in dipstick receiver and a high strength magnetic drain plug in each sump for total oil drainage.

**Pan Capacity is 7 Qts. Plus Filter —
Sump Measures 6¾" Deep in Front, 10" Deep in Rear**

- Ford 289, 302 (Trucks, Broncos 1966 & Up)... . **30501**

Oil Pump and Pick-Up Required:

Pickup	18430
Oil Pump (Melling M83HV)	18800
Oil Pump Shaft	22500
Windage Tray	32212
Tray Install Kit	81157
Oil Pan Gasket	40300
1 Piece Pan Gasket	41003
Dipstick	22040

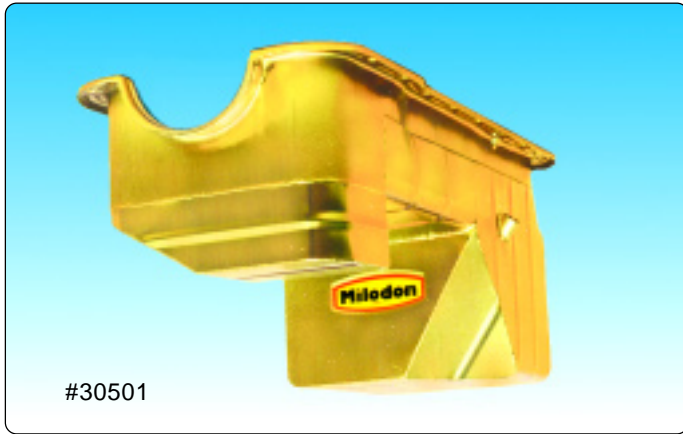

#30501



351W REAR SUMP

Off-road pan for 2 and 4 wheel drive, rear sump trucks and Broncos. Deep sump in rear for extra capacity. Features horizontal baffles for increased oil control and dirt and water tight Ford style screw-in dipstick receiver with high strength magnetic drain plug in each sump for total oil drainage.

**Pan Capacity is 8 Qts. Plus Filter —
Sump Measures 6¾" Deep in Front, 10" Deep in Rear**

- Ford 351W (Truck & Bronco 1978 & Up)... . **30530**

Pan Capacity is 7 Qts. Plus Filter —

- Ford 351W (1966-77 Bronco)... . **30531**

Oil Pump and Pick-Up Required:

Pickup	18440
Oil Pump Shaft	22560
Oil Pan Gasket	40350
1 Piece Pan Gasket	41004
Oil Pan Bolts	85010
Windage Tray	32217
Tray Install Kit	81167
Dipstick	22040

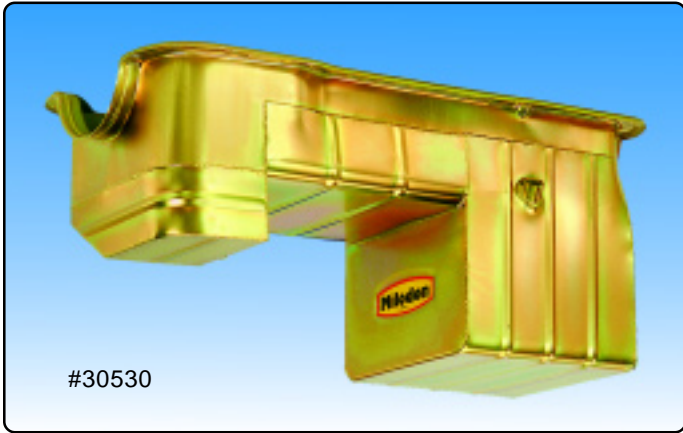

#30530



4x4 TRUCK & OFF-ROAD OIL PANS

- Ford (cont.) -

351C & 400M REAR SUMP

For 2 and 4 wheel drive, rear sump trucks including Bronco. The deep rear sump features horizontal oil control baffles that allow increased capacity as well as improved oil control. Features a factory style fitting to attach a dirt and water tight screw in dipstick tube. High strength magnetic drain plug included.

Pan Capacity is 8 Qts. Plus Filter —

Sump Measures 6½” Deep in Front, 10” Deep in Rear

- Ford 351C (Truck & Bronco 1978 & Up) **30520**

Oil Pump and Pick-Up Required:

Pickup with Melling M84AHV	18435
Oil Pump Shaft	22565
Oil Pan Gasket	40400
Oil Pan Bolts	85010
Oil Pan Studs	81310
Windage Tray	32222
Tray Install Kit	81151
Dipstick	22040

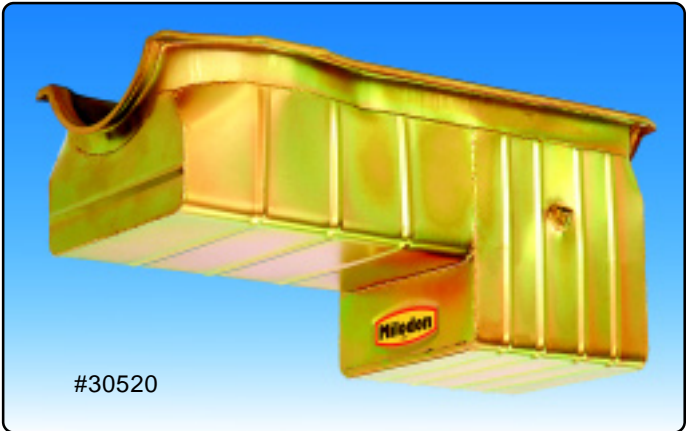

#30520

Note: Rear sump pickups must mount between the main cap and the main bolt with no bolt extensions required or desired. Do not use bolts with extensions or any other upward spacing.

390-428 REAR SUMP

Designed for applications where extra rough terrain and jumping may be encountered. For 2 and 4 wheel rear sump trucks including 1978 and up Bronco. Deep rear sump features horizontal oil control baffles that allow increased capacity as well as improved oil control. Features a factory style fitting to attach a dirt and water tight screw in dipstick tube and high strength magnetic drain plug.

Pan Capacity is 8 Qts. Plus Filter —

Sump Measures 4½” Deep in Front, 10” Deep in Rear

- 390-428 **30550**

Oil Pump and Pick-Up Required:

Pickup with Melling M57HV	18445
Oil Pump Shaft	22550
Oil Pan Gasket	40450
Oil Pan Bolts	85020
Oil Pan Studs	81320
Dipstick	22040



#30550



429-460 REAR SUMP

For 2 and 4 wheel rear sump trucks including Broncos. The deep rear sump features horizontal oil control baffles that allow increased capacity as well as improved oil control. Features a factory style fitting to attach a dirt and water tight screw in dipstick tube. High strength magnetic drain plug included.

Pan Capacity is 8 Qts. Plus Filter —

Sump Measures 6½” Deep in Front, 10¾” Deep in Rear

- 429-460 (Truck, Bronco 78 & Up) **30570**

Oil Pump and Pick-Up Required:

Pickup, Bolt-on	18451
Oil Pump	Melling M84D
Oil Pump Shaft	22570
Oil Pan Gasket	40500
Oil Pan Bolts	85010
Oil Pan Studs	81310
Windage Tray	32227
Tray Install Kit	81190
Dipstick	22040



#30570



4x4 TRUCK & OFF-ROAD OIL PANS

- Chrysler -

318-340 & 360 REAR SUMP

For street cruising to heavy off road use. Sump at the rear has additional oil control for power and increased capacity. Uses a factory Ford style screw-in or Milodon CNC stainless steel dipstick. Fits two and four wheel drive vehicles trucks. High strength magnetic drain plug included.

Pan Capacity is 8 Qts. Plus Filter — 10 3/4" Sump Depth

- 318-340 **30980**
- 360 **30985**

Oil Pump and Pick-Up Required:

Pickup with Melling M72HV	18460
Oil Pan Gasket - 318-340	40600
Oil Pan Gasket - 360	40650
Windage Tray - 318, 340 & 360	32230
Tray Install Kit	81151
Oil Pump Drive Steel Gear	21530
Oil Pump Drive Bronze Gear	21535
Oil Pan Bolts	85020
Oil Pan Studs	81320
Dipstick	22040



#30980

383-440 & HEMI REAR SUMP

Designed for extra rough offroad terrain or heavy street use. For 2WD, 4WD trucks. Pan has additional oil control for power and increased capacity for longevity. Uses a factory Ford style screw-in or Milodon CNC stainless steel dipstick. Stock dipstick location can be used but stick will have to be cut off to just touch the floor on the pan in the front. There will only be 1/2" of oil depth there but it can work. High strength magnetic drain plug included.

Pan Capacity is 8 Qts. Plus Filter — 8" Sump Depth

- 383-440 **30890**

Oil Pump and Pick-Up Required:

Pickup, 3/8" Pipe Inlet	18455
Pickup, Hemi & Oversized Wedge, 1/2" Pipe Inlet	18456
Oil Pump (Melling)	M63HV
Single Line Static External Pick-Up (Hemi)	21000
Single Line Static External Pick-Up (Wedge)	21010
Oil Pump Shaft Assembly	21505 or 21525
Windage Tray	32000
Oil Pan Gasket	40700
Oil Pan Bolts	85020
Oil Pan Studs	81320
Dipstick, Screw In Pan Location	22040
Dipstick, Stock Block Location	22070

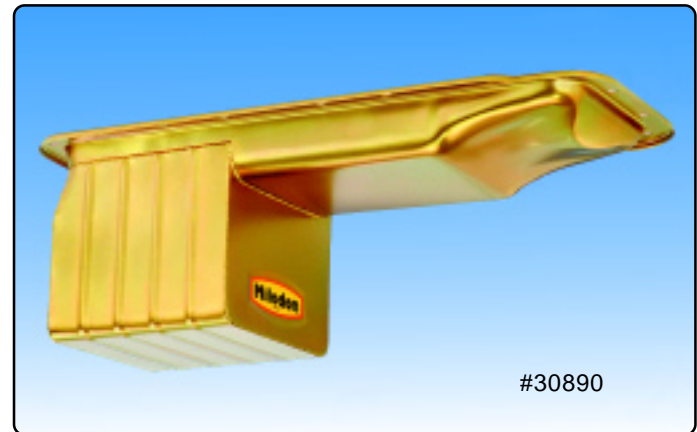

#30890

Big and Small Block Chrysler Dipstick Note:

The dipstick has been relocated into the rear sump of the oil pan. A screw-in style Ford bung welded into the pan will accept a late model Ford or the stainless CNC Milodon dipstick #22040.

383-440 & HEMI STOCK REAR SUMP

Designed for stock replacement for 2WD, 4WD trucks or other rear sump applications. Pan has additional oil control for power and increased capacity for longevity. Uses a factory Ford style screw-in or Milodon CNC stainless steel dipstick. Stock dipstick location can be used but stick will have to be cut off to just touch the floor on the pan in the front. There will only be 1/2" of oil depth there but it can work. High strength magnetic drain plug included.

Pan Capacity is 5 Qts. Plus Filter — 6" Sump Depth

- 383-440 **30895**

Oil Pump and Pick-Up Required:

Pickup, 3/8" Pipe Inlet	18457
Oil Pump (Melling)	M63HV
Oil Pump Shaft Assembly	21505 or 21525
Windage Tray	32000
Oil Pan Gasket	40700
Oil Pan Bolts	85020
Dipstick, Screw In Pan Location	22040
Dipstick, Stock Block Location	22070

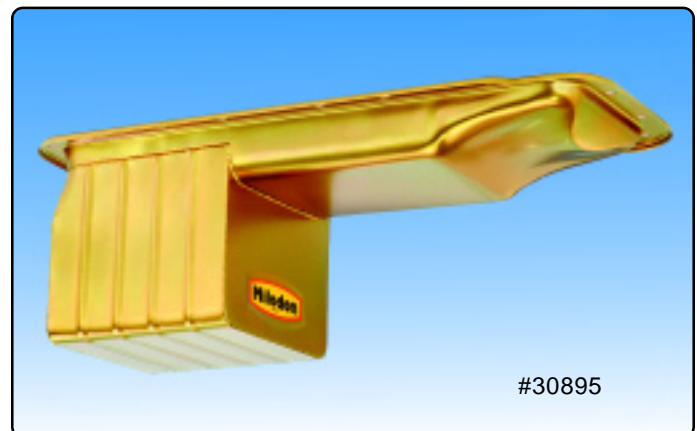

#30895



MONSTER TRUCK

- Big Block Chevy Reversed Sump-

454-632

MONSTER TRUCK

Especially for Monster truck use where engine is reverse mounted. This pan is built of extra heavy gage material. Pan is double baffled with a full length windage tray providing maximum power by controlling oil movement in severe conditions. Water tight leakproof dipstick pan mounted.

Mk IV / V & Gen VI will fit 4½" stroke with most aluminum rods.

**Pan Capacity is 9 Qts. Plus Filter —
8" Deep in Front, 7" Deep in Rear of Motor**

- 396-454 Mark IV ('65-'90) **31310**
- 8.2 Litre Mark V & Gen VI **31311**

Oil Pump and Pick-Up Required:

Extreme Duty Pickup	18476
Oil Pump	18760
Pump Drive Shaft	23060
Rear Pan Baffle.....	32505

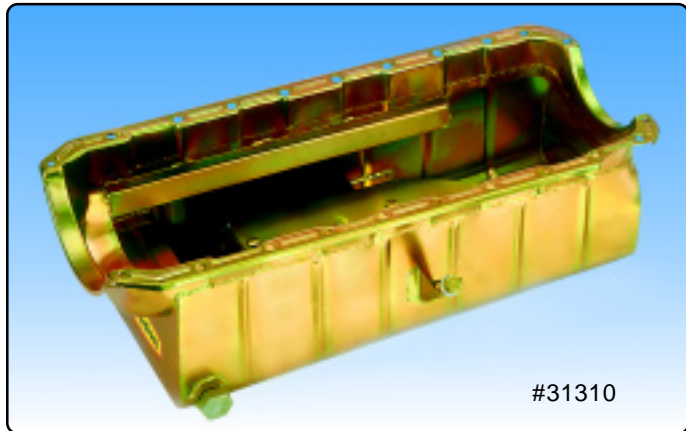

#31310

- Ford Reversed Sump-

429-460

MONSTER TRUCK

Especially for Monster truck use where engine is reverse mounted. This pan is built of extra heavy gage material. Pan is double baffled with a full length windage tray providing maximum power by controlling oil movement in severe conditions.

**Pan Capacity is 9 Qts. Plus Filter —
7½" Front Depth, 8¼" Rear Depth**

- 429-460..... **31494**

Oil Pump and Pick-Up Required:

Pick-Up (Bolt On)	18494
Oil Pump - Melling	M84 D or M84 DHV
Oil Pump Shaft	22570
Oil Pan Gasket.....	40500
1 Piece Oil Pan Gasket	41005
Pan Bolts.....	85010
Pan Studs	81310



#31494



The Black Stallion team do 70 shows a year & needs the best.



All Bigfoot trucks have run Milodon oil pans since 1985